

QUAD 150 – HIGH FRONT GUTTER

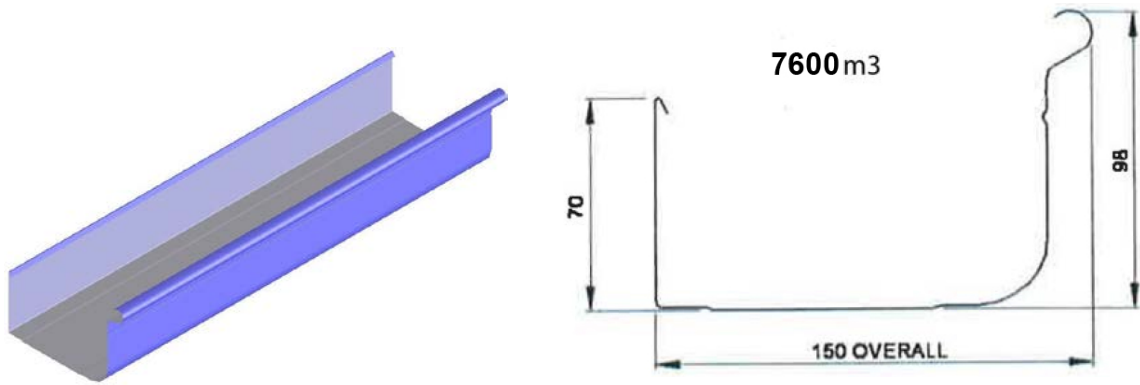

USE:	Residential housing projects – high rainfall and large roofs	
QUALITIES:	High tensile steel supplied by Bluescope Steel Limited High front designed to hide edge of roof sheets or tile edges Unslotted to effect smooth lines Available in all COLORBOND® colours & ZINCALUME®	
PERFORMANCE:	Designed to achieve Gutter requirements in BCA 2016 Section 3.5.2 Capable of carrying in excess of 32m ² of roof area per downpipe in SE QLD	
DESIGN:	Height	98mm
	Overall Width	150mm
	Lengths	Made to order up to 8 mtr
	Effective cross sectional area (AS 2179)	7600 mm ³
PROPERTIES:	ZINCALUME® alloy coated AZ150 conforms to AS1397 COLORBOND® coated steel in accordance with AS2728 – Category 3 A plastic film protects this product from scratches during fixing	
	Base Metal Thickness BMT (mm)	0.42
	Tensile Strength (MPa)	550
	Mass (kg/lineal mtr)	ZA 1.10 CB 1.12
INSTALLATION:	Allow for gutter “fall” of at least 1 in 500 from the designated high points	
PANTEX FASCIA:	Quad 150 HF gutter can be fixed to Pantex metal fascia with Spring Clips, Overstraps & Gutter Spacer - should be spaced every 900mm as a cluster	
OTHER FASCIA:	Use internal gutter brackets spaced at 900mm for metal or timber fascia Remove plastic coating from finished installation	
ACCESSORIES:	Spring Clips	Overstraps
	Internal gutter brackets	5mm Gutter Spacer
	Stop ends – left and right hand	Return ends – left and right hand
	Internal and external corners	